



Please write clearly in block capitals.

Centre number

--	--	--	--	--

Candidate number

--	--	--	--

Surname

---

Forename(s)

---

Candidate signature

---

I declare this is my own work.

# GCSE MATHEMATICS

# F

Foundation Tier

Paper 1 Non-Calculator

Wednesday 6 November 2024 Morning Time allowed: 1 hour 30 minutes

## Materials

For this paper you must have:

- mathematical instruments
- the Formulae Sheet (enclosed).

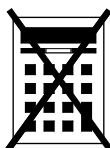

You must **not** use a calculator.

## Instructions

- Use black ink or black ball-point pen. Draw diagrams in pencil.
- Fill in the boxes at the top of this page.
- Answer **all** questions.
- You must answer the questions in the spaces provided. Do not write outside the box around each page or on blank pages.
- If you need extra space for your answer(s), use the lined pages at the end of this book. Write the question number against your answer(s).
- Do all rough work in this book. Cross through any work you do not want to be marked.

## Information

- The marks for questions are shown in brackets.
- The maximum mark for this paper is 80.
- You may ask for more answer paper, graph paper and tracing paper. These must be tagged securely to this answer book.

## Advice

In all calculations, show clearly how you work out your answer.

For Examiner's Use	
Pages	Mark
2–3	
4–5	
6–7	
8–9	
10–11	
12–13	
14–15	
16–17	
18–19	
20–21	
<b>TOTAL</b>	



N 0 V 2 4 8 3 0 0 1 F 0 1

Answer **all** questions in the spaces provided.

Do not write  
outside the  
box

1 (a) Write down the value of  $\sqrt{49}$

[1 mark]

Answer \_\_\_\_\_

1 (b) Work out the value of  $3^3$

[1 mark]

\_\_\_\_\_

Answer \_\_\_\_\_

1 (c) Write 10 000 as a power of 10

[1 mark]

\_\_\_\_\_

\_\_\_\_\_

Answer \_\_\_\_\_

2 1 pound = 16 ounces

Work out the number of ounces in 3 pounds.

[2 marks]

\_\_\_\_\_

\_\_\_\_\_

\_\_\_\_\_

Answer \_\_\_\_\_ ounces



3 (a) Write  $\frac{3}{2}$  as a mixed number.

[1 mark]

---

Answer \_\_\_\_\_

3 (b) Work out  $\frac{1}{5} + \frac{1}{5}$

[1 mark]

---

Answer \_\_\_\_\_

4 (a) Write down **all** the factors of 20

[2 marks]

---

---

---

Answer \_\_\_\_\_

4 (b) Mica says,

“When two multiples of 5 are added, the answer is always a multiple of 10”

Give **one** example to show that he is wrong.

[1 mark]

---

---



- 5 Put these values in order of size, starting with the smallest.

80%

0.7

 $\frac{3}{4}$ **[2 marks]**

---

---

---

---

Answer \_\_\_\_\_

- 6 Sally buys two hats and three scarves.

The **total** cost is £28.50

Each hat costs £4.50

Work out the cost of each scarf.

**[4 marks]**

---

---

---

---

---

---

---

---

Answer £ \_\_\_\_\_



Do not write outside the box

- 7 120 people visit a maze.  
 80 are children, the rest are adults.  
 At the start of the maze you can turn left or right.  
 45 children turn left.  
 75 people in total turn left.

7 (a) Complete the frequency tree.

[4 marks]

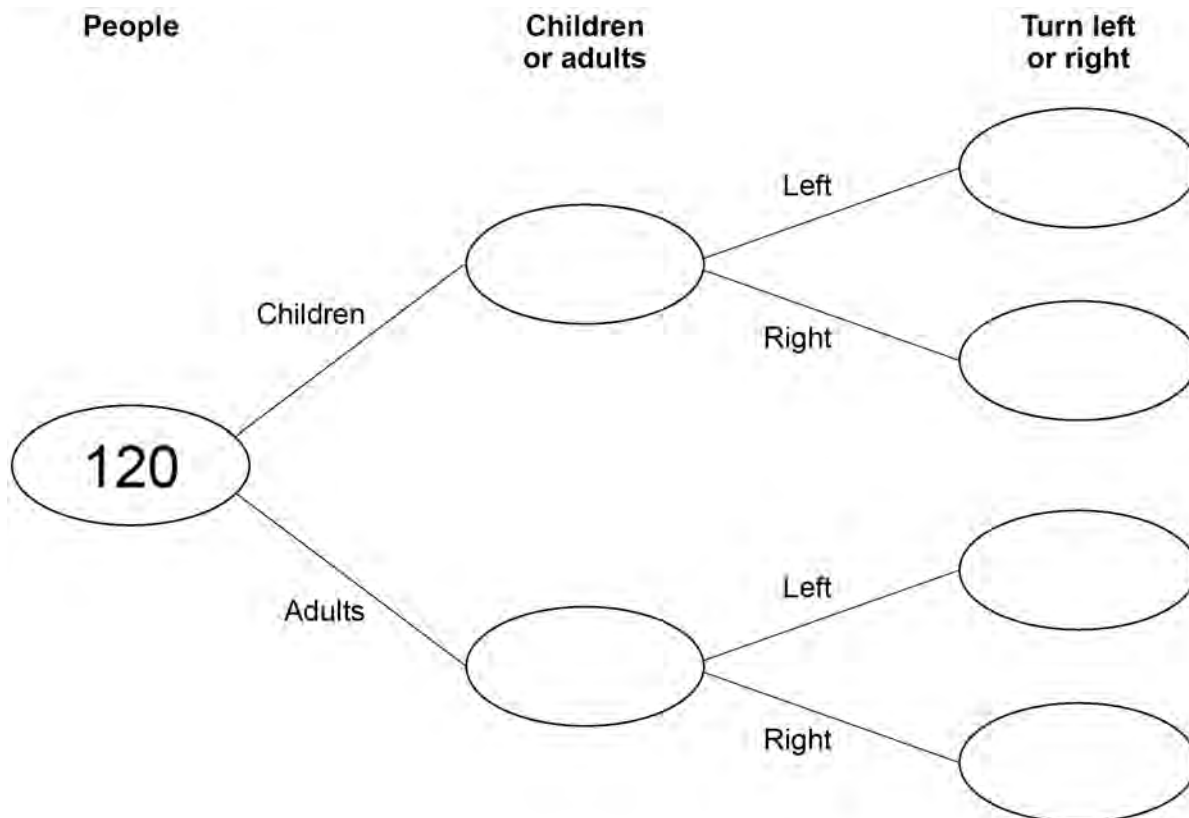

7 (b) What fraction of the **children** turn left?  
 Give your answer in its simplest form.

[2 marks]

---



---

Answer \_\_\_\_\_

Turn over ►



8

The table shows information about where students prefer to revise.

Library	Home	In class
30	68	37

Ed draws this bar chart to represent the data.

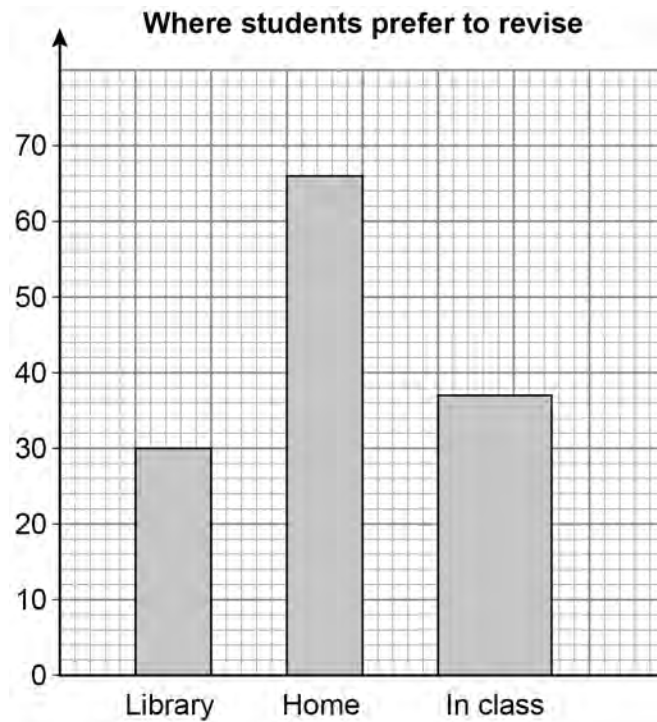

Write down **three** mistakes he has made.

**[3 marks]**

Mistake 1 \_\_\_\_\_

\_\_\_\_\_

Mistake 2 \_\_\_\_\_

\_\_\_\_\_

Mistake 3 \_\_\_\_\_

\_\_\_\_\_



- 9** A number is picked at random from the first three positive odd numbers.  
A number is picked at random from the first four prime numbers.  
The two numbers are **multiplied** to get a score.

- 9 (a)** Complete the table.

**[4 marks]**

		prime			
		2	3	5	7
odd	×				
1					
5			15		

- 9 (b)** What is the probability that the score is a square number?  
Give your answer as a fraction.

**[2 marks]**

---



---



---

Answer \_\_\_\_\_



Do not write  
outside the  
box

**10 (a)** Simplify fully  $8m + 4 - 2m + 7$

**[2 marks]**

---

---

Answer \_\_\_\_\_

**10 (b)** Simplify fully  $\frac{1}{2}c \times 6d$

**[2 marks]**

---

---

Answer \_\_\_\_\_



11

Do not write  
outside the  
box



The multipack costs 10% **less than** 6 single bags.

Work out the cost of the multipack.

**[4 marks]**

---

---

---

---

---

---

---

---

---

---

Answer £ \_\_\_\_\_

—  
8

Turn over ►



12 Write the ratio  $6 : 2$  in the form  $n : 1$

[1 mark]

---

Answer \_\_\_\_\_ : 1

13  $x$  and  $y$  are two **different positive** numbers.

For each statement, tick the correct box.

[2 marks]

	Always true	Sometimes true	Never true
$x + y$ is positive	<input type="checkbox"/>	<input type="checkbox"/>	<input type="checkbox"/>
$x - y$ is negative	<input type="checkbox"/>	<input type="checkbox"/>	<input type="checkbox"/>

---

---

---



- 14 (a) On the grid, draw a shape **congruent** to triangle A.

[1 mark]

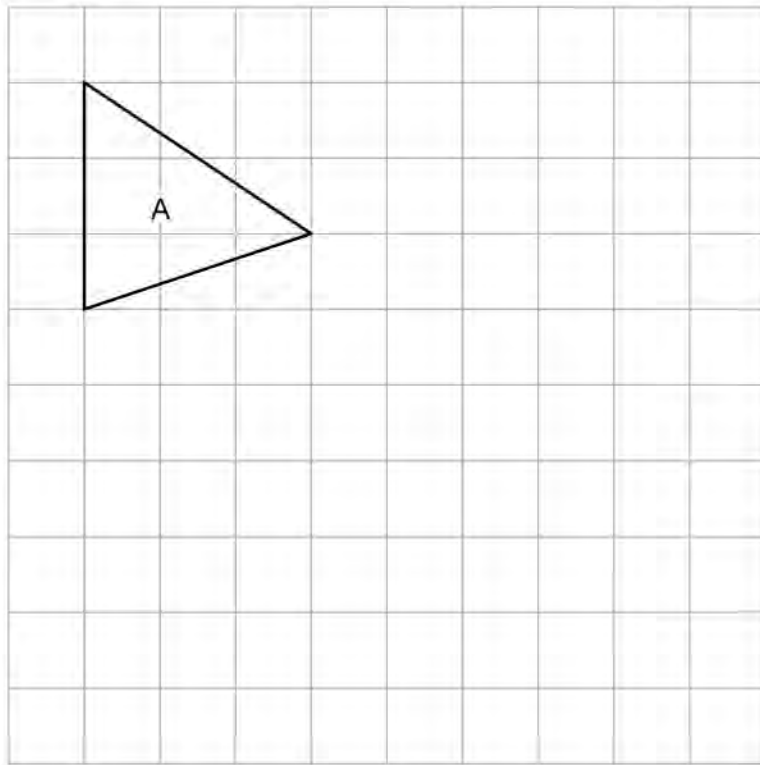

- 14 (b) On the grid, **enlarge** shape B by scale factor  $\frac{1}{3}$

[2 marks]

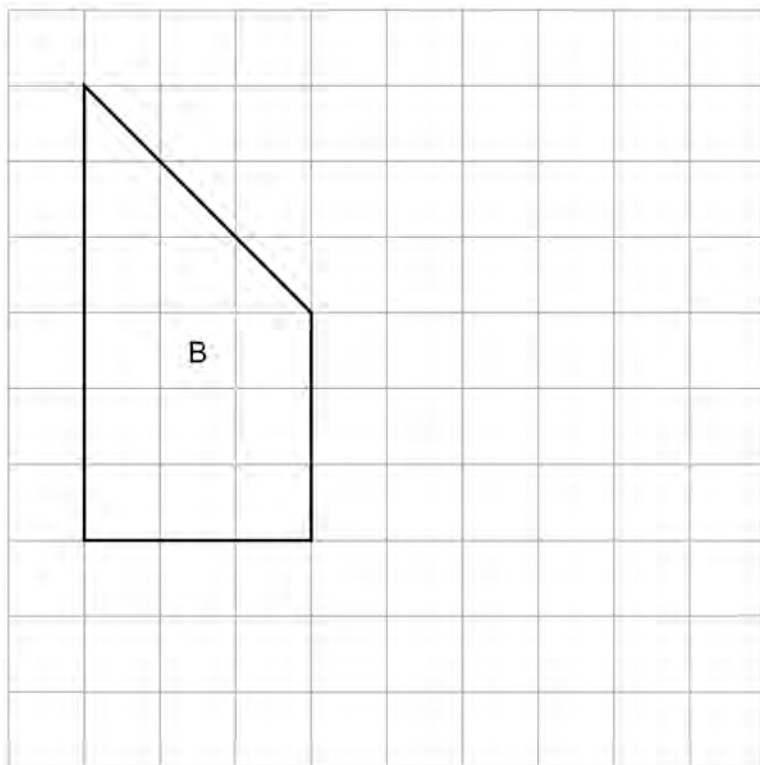

Turn over ►



15

35 books are either for adults or for children.

Do not write  
outside the  
box
$$\text{number for adults} : \text{number for children} = 6 : 1$$
How many **more** books are for adults than for children?**[3 marks]**

---

---

---

---

---

---

---

Answer \_\_\_\_\_



16 This shape is made from a semicircle and a square.

Do not write outside the box

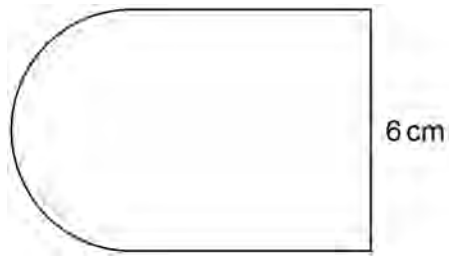

Not drawn accurately

On the centimetre grid below, make an accurate drawing of the shape.

[2 marks]

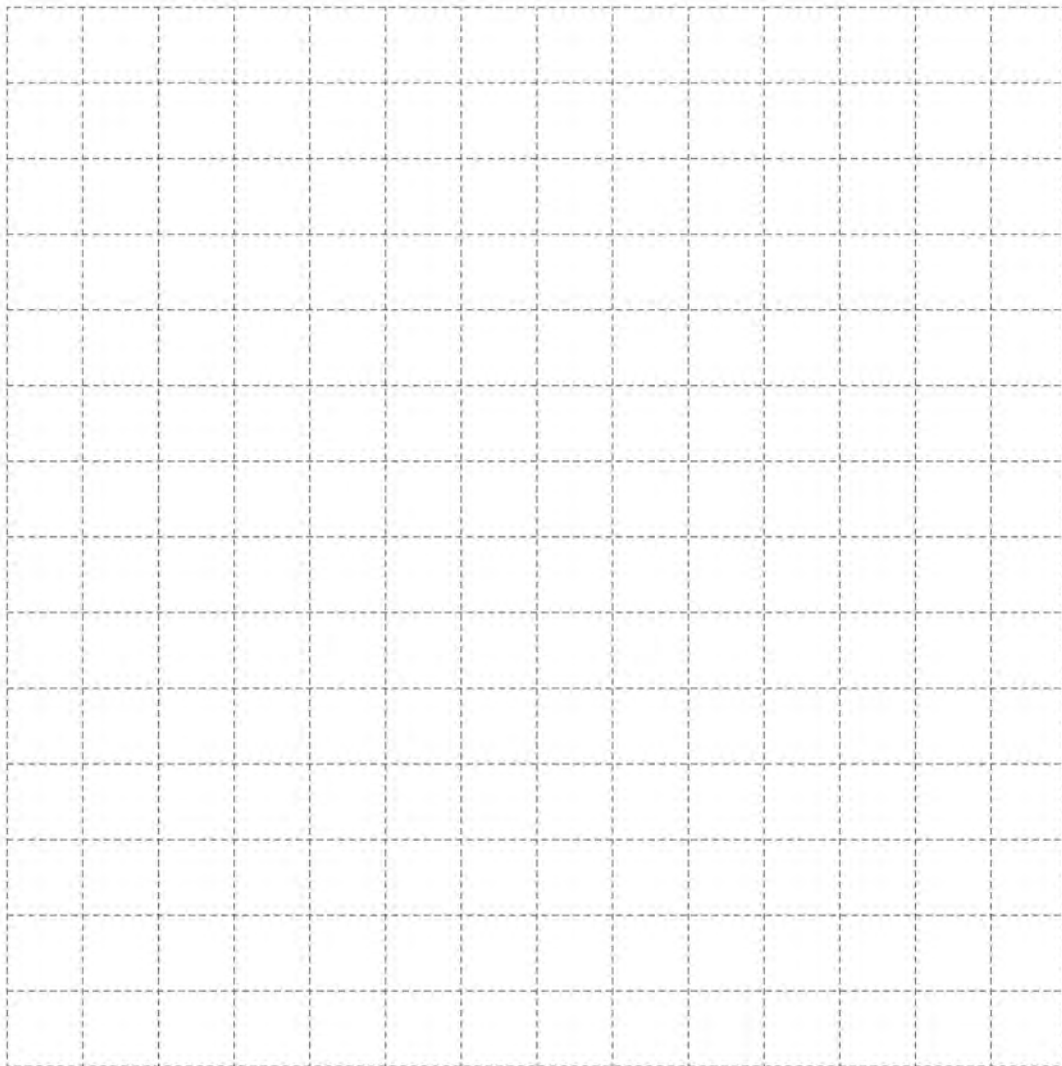

5

Turn over ►



17

A car travels 4 miles in 5 minutes.

Work out the average speed in miles per hour.

**[3 marks]**

---

---

---

---

---

---

---

Answer \_\_\_\_\_ mph

*Do not write  
outside the  
box*



18

$J(0, 12)$  and  $K(5, 10)$  are points on the straight line  $JKLM$ .

Do not write  
outside the  
box

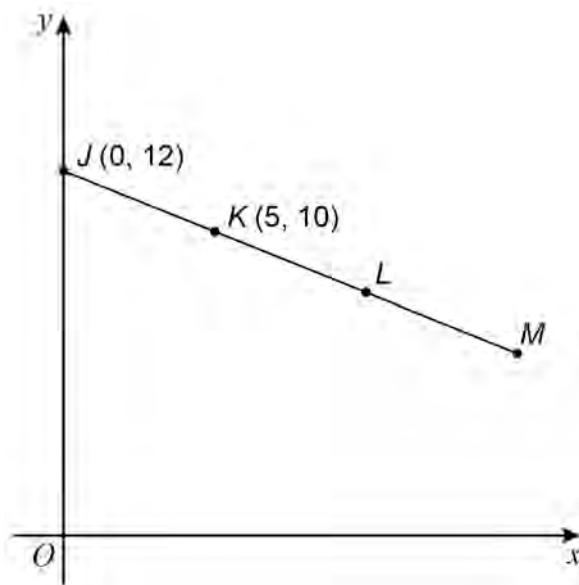

Not drawn  
accurately

$$JK = KL = LM$$

Work out the coordinates of  $M$ .

[3 marks]

---

---

---

---

---

---

---

---

Answer ( \_\_\_\_\_ , \_\_\_\_\_ )

6

Turn over ►



19 Work out the value of  $1.5^2$

[2 marks]

---



---

Answer \_\_\_\_\_

20 (a) Complete this number machine so that  $y = 4x + 5$

[1 mark]

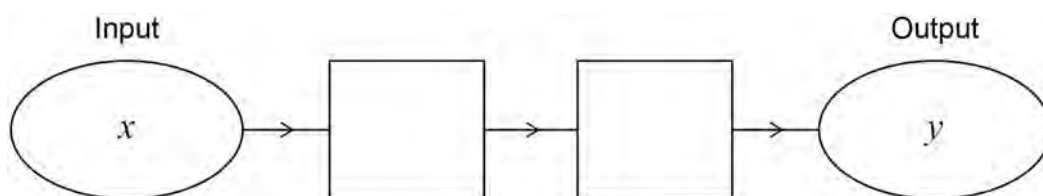

20 (b) Complete this number machine so that  $y = 3x - 24$

[1 mark]

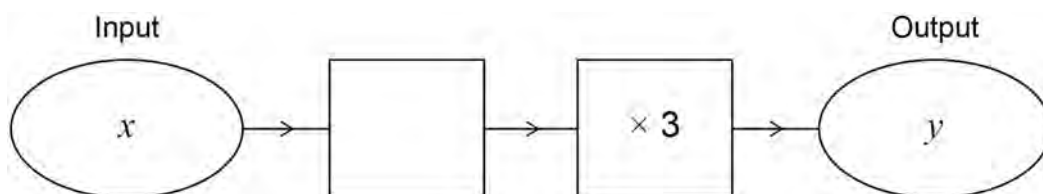

20 (c) Complete this number machine so that  $y = x$

[1 mark]

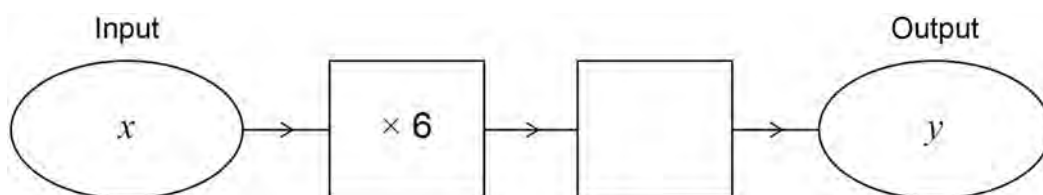

21 Each number in a list is increased by 10

Tick **one** box for each statement.

[3 marks]

	True	False	Cannot tell
The mode is increased by 10	<input type="checkbox"/>	<input type="checkbox"/>	<input type="checkbox"/>
The median is increased by 10	<input type="checkbox"/>	<input type="checkbox"/>	<input type="checkbox"/>
The range is increased by 10	<input type="checkbox"/>	<input type="checkbox"/>	<input type="checkbox"/>

22 (a) Write the missing term in the geometric progression.

[1 mark]

1      4      16      \_\_\_\_\_      256

22 (b) A Fibonacci-type sequence begins

5      -9

The sequence is continued by adding the previous two terms.

Work out the next **two** terms.

[2 marks]

---



---

Answer \_\_\_\_\_ and \_\_\_\_\_



23 Here is a solid prism.

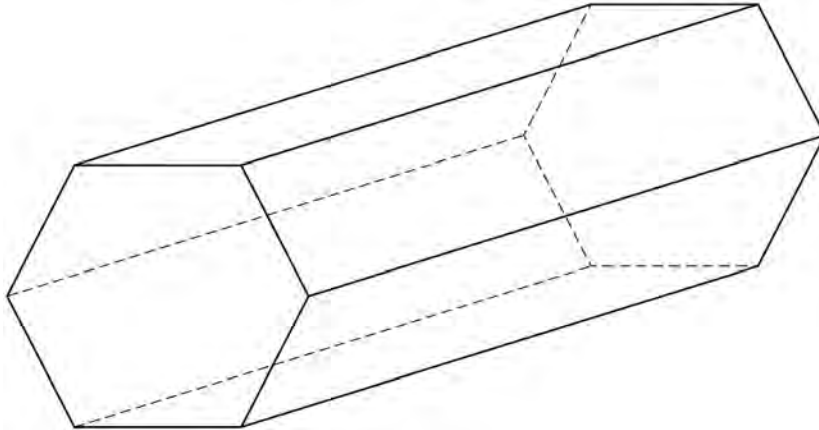

23 (a) How many faces does the prism have?

[1 mark]

Answer \_\_\_\_\_

23 (b) The prism has

$$\text{volume} = 3500 \text{ cm}^3$$

and

$$\text{length} = 20 \text{ cm}$$

Work out the area of the cross-section of the prism.

[2 marks]

---

---

---

---

Answer \_\_\_\_\_  $\text{cm}^2$



Do not write  
outside the  
box

24 Work out  $1\frac{1}{5} - \frac{3}{10}$

Give your answer as a fraction.

[2 marks]

---

---

---

---

---

Answer \_\_\_\_\_

25 Write down the value of  $\sin 90^\circ$

[1 mark]

Answer \_\_\_\_\_

Turn over for the next question

6

Turn over ►



26

A large circle and a small circle are shown.

The radius of the large circle is 12 cm

$$\text{radius of large circle} : \text{radius of small circle} = 4 : 1$$

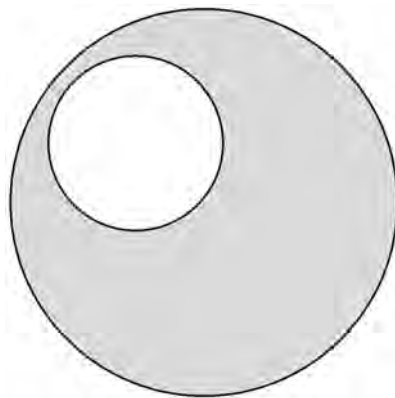

Not drawn  
accurately

Work out the shaded area.

Give your answer in terms of  $\pi$

[4 marks]

---

---

---

---

---

---

---

---

Answer \_\_\_\_\_  $\text{cm}^2$



**27 (a)** In this part, assume that each person works at the same rate.

10 people can complete a job in 9 hours.

If 15 people work on the same job, how many hours will it take to complete the job?

**[2 marks]**

---

---

---

---

Answer \_\_\_\_\_ hours

**27 (b)** In fact, of the 15 people

6 work at a slower rate

9 work at a faster rate.

What does this mean about the number of hours it will take to complete the job?

Tick **one** box.

**[1 mark]**

It is greater than the answer to (a)

It is the same as the answer to (a)

It is less than the answer to (a)

It is not possible to say

**END OF QUESTIONS**



**There are no questions printed on this page**

*Do not write  
outside the  
box*

**DO NOT WRITE ON THIS PAGE  
ANSWER IN THE SPACES PROVIDED**





